

General Description

The CS9803 is a passive infra-red controller, using analog mixing digital design technique and manufactures by CMOS process which can either driver TRIAC or RELAY depending on user's choice.

With special noise immunity technique, CS9803 is the most stable passive infrared controller you can find on the market. More than this, there are few components needed in its application circuit which can reduce material cost and increase competitive.

Features

- Operating voltage: 4.5V ~ 5.5V (DC)
- Operating current \leq 1mA
- CDS input
- Pulse output for TRIAC drive or level output for relay drive
- Built-in 2-stage operational amplifier
- Adjustable output on time duration
- On-chip regulator for PIR sensor
- Zero-crossing triggering
- Application:
 - Home security system
 - Auto light system for garden, garage, hallway, staircase, porch, bathroom, etc.
 - Auto switch for ventilation fan
 - Auto notice system for office, storage, etc.
- Package: DIP16



Absolute Maximum Ratings

Supply Voltage:-0.3 ~ 6.0V
Operating Temperature:-25 ~ +70°C
Input Voltage:-0.5 ~ (V _{DD} +0.5) V
Storage Temperature:-55 ~ +150°C
Power Dissipation: 500mW

Pin Description

No.	Pin Name	I/O	Function Description
1	UOU1	O	First stage OP amp output
2	NII1	I	First stage OP amp positive input
3	II1	I	First stage OP amp negative input
4	VREF	O	Stable reference voltage
5	GND	P	System ground
6	TB	I	System clock
7	QTEST	I	Test only
8	TCI	I	To set up the timing of how long Triac or relay is active
9	CDS	I	Detect CDS
10	TRIAC	O	TRIAC output
11	RELAY	O	RELAY output
12	ZCD	I	Detect zero cross
13	VDD	P	Power ground
14	II2	I	Second stage OP amp negative input
15	NII2	I	Second stage OP amp positive input
16	UOU2	O	Second stage OP amp output

CS9803

Electrical Characteristics (Ta=25°C, VDD=5.0V, VSS=0V)

Symbol	Characteristic	Test Condition	Min.	Typ.	Max.	Unit
VDD	Supply voltage	---	4.5	5	5.5	V
IOP	Operating current	no load	---	---	1	mA
VREF	Stable voltage	V _{OH} =3.3V	2.8	3.1	3.3	V
IREF	Source current of VREF		200	---	---	μA
Avo	Op amp pen loop gain		---	60	---	dB
IOL1	TRIAC sink current		---	---	15	mA
IOH1	TRIAC source current		50	---	---	μA
IOL2	RELAY sink current		---	---	5	mA
IOH2	RELAY source current		---	---	5	mA

Application Circuit

1、 TRIAC Application

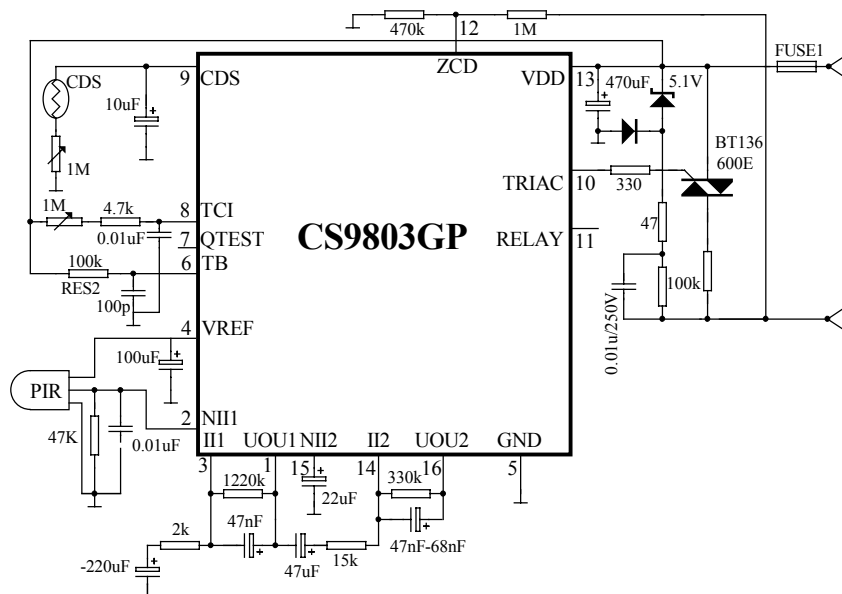

2、 RELAY Application

